

ELC – Applied Electronics

T008

Thursday, 07/11/2013

8:30 - 11:30 AM

WORKFORCE DEVELOPMENT AUTHORITY



P.O.BOX 2707 Kigali, Rwanda Tel: (+250) 255113365

**ADVANCED LEVEL NATIONAL EXAMINATIONS, 2013,
TECHNICAL AND PROFESSIONAL TRADES**

EXAM TITLE : Applied Electronics

OPTION: Electricity (ELC)

DURATION: 3hours

INSTRUCTIONS:

The paper contains **three (3)** sections :

Section I: Fifteen **(15)** questions, all **Compulsory;** **55marks**

Section II: Five **(5)** questions, **Choose any three (3);** **30marks**

Section III: Two **(2)** questions, **choose any ONE (1)** **15marks**

Section I : Attempt all the 15 questions 55marks

01. How many electrons are in the last orbit of a semiconductor atom? **1mark**
02. What is the cause of barrier potential in a P-N junction? **1mark**
03. What is the role of a commutating capacitor used in a bistable multivibrator circuit? **1mark**
04. Which component is represented bellow? Give the corresponding symbol. **2marks**

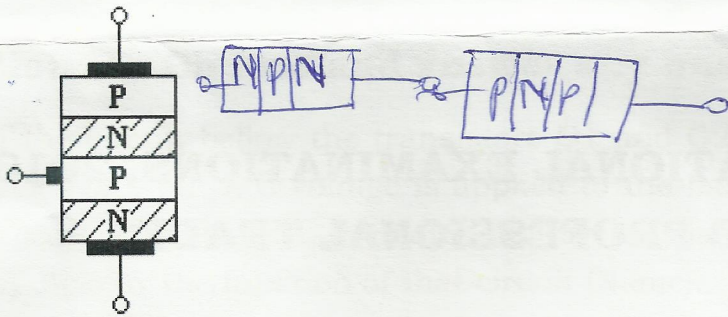

05. What are the essential parts of an oscillator circuit? **2marks**
Sinusoidal Non sinusoidal
06. How the input resistance R_i and the output resistance R_o of the basic amplifier are modified in case of a voltage shunt negative feedback amplifier system? **2marks**
07. Identify the main characteristics of a Darlington Amplifier. **3marks**
08. Determine the maximum DC voltage across the load if the peak value of the input voltage to a half wave rectifier is 28.28 volts and no filter is used. **3marks**
09. If the output filter capacitor of $1000\mu\text{F}$ in a power supply is replaced by $2000\mu\text{F}$, what will be the effect? **4marks**
10. Identify different types of relays. **4marks**
11. Identify different methods of biasing a bipolar junction transistor (BJT). **5marks**
12. Classify materials into three groups on the basis of the number of valence electrons. **6marks**
- Semi conductor
- Insulator
- Conductor
13. Discuss the terminal properties of an ideal operational amplifier. **6marks**
- input, output, frequency
14. Consider the following diagram which represents a drain characteristic of field effect transistor with shorted gate, and answer to these questions:
- a) What indicate each one point A, B, C, and D? **4marks**
- b) Identify the regions represented by R_1 , R_2 , and R_3 ? **3marks**

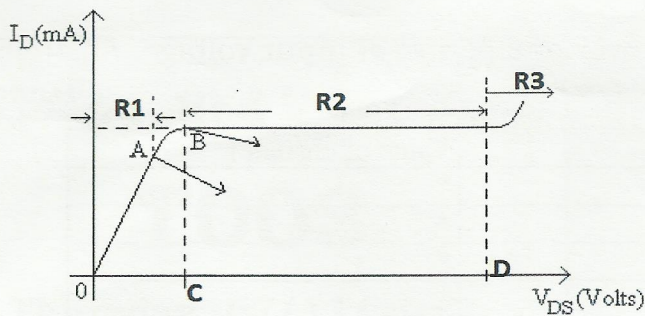

15. Determine the exact range in which the resistor represented below may be. **8marks**

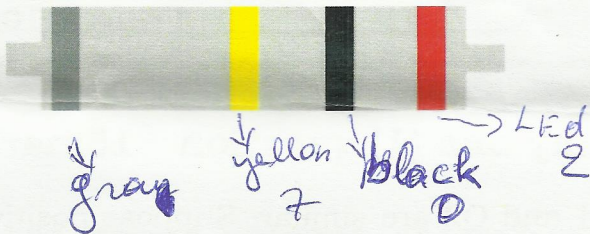

Section II: Choose and Answer any three (3) questions 30marks

16. For the circuit shown below, find the maximum and minimum values of zener diode current in mA. **10marks**

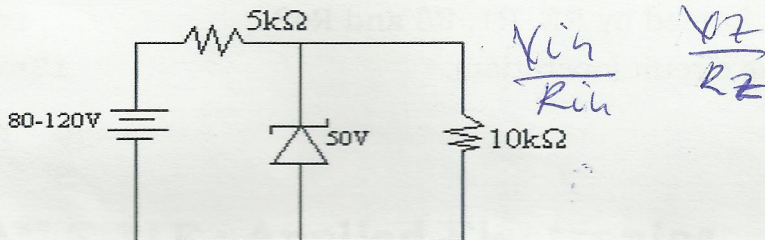

17. A 6 V / 2.5 mA relay is connected in the output stage of a transistor. The coil is made of aluminium having a temperature coefficient of 0.004. The resistance of the coil is 600 Ω at 32°C. Calculate the resistance of the coil at 42°C. **10marks**

18. Consider the circuit represented by the figure below and determine the voltage on the points A, B, C, D, by indicating the polarities. Identify the function and general application of such circuit. **10marks**

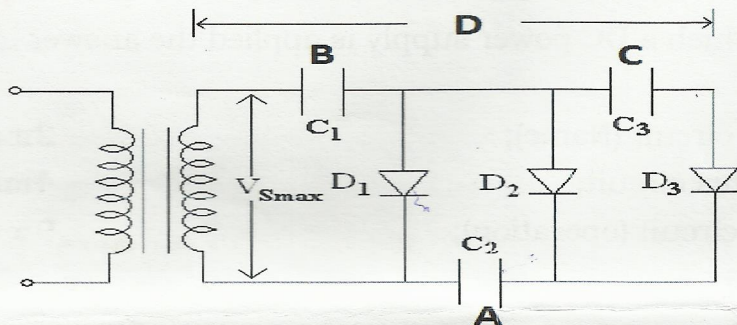

19. Study the behavior of the circuit shown in the figure below:

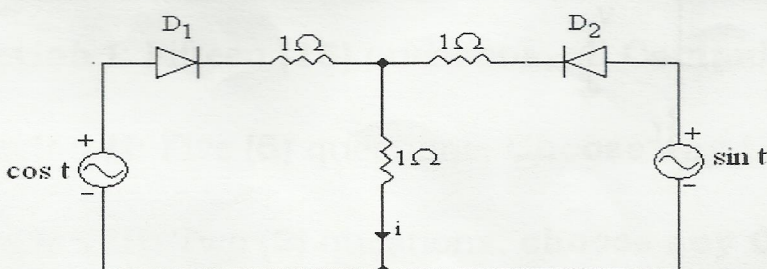

Determine the expression of current i over one period of input voltage. Assume the diodes to be ideal. Complete the following table. **10marks**

Interval	Diode status	Value of current i
$0 \leq t \leq \pi/2$	*	*
*	*	*
*	*	*
$3\pi/2 \leq t \leq 2\pi$	*	*

20. Identify different characteristics of thyristors related to the current and power dissipation. **10marks**

Section III: Choose and answer any one (1) question 15marks

21. In the circuit bellow the transistors Q1 and Q2 are similar. Suppose positive half cycles of input A.C voltage is applied to the base of Q1 and suppose this positive voltage is sufficient to overcome the reverse bias on the base of Q2.

- a) Specify the function of that circuit (Name). **1mark**
- b) What is the role of the set formed by R_E , R_1 , R_3 and R_4 ? **1mark**
- c) Explain the behavior of the circuit (operation). **13marks**

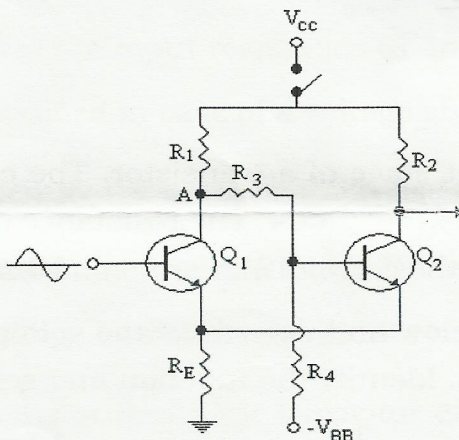

22. Consider the circuit bellow on which a DC power supply is applied the answer to the following questions:

- a) Specify the function of that circuit (Name); **2marks**
- b) Identify two main parts of this circuit; **4marks**
- c) Explain the behavior of the circuit (operation); **9marks**

